



Head Office: 323 Church Street, Penrose 1061, Auckland. P. O Box 112 001 Penrose, Auckland.
 Ph: 09 550-2805, E mail: sales@driveshaftnz.co.nz

2 Piece Shaft using Your Slip yoke and Regular Rear Pinion Yoke

Important: Suspension must be at Normal Ride Height.

Wheels on Ground or Diff. Loaded (wheels not hanging on lift)

Please take all length dimensions from vehicle - NOT the old driveshaft

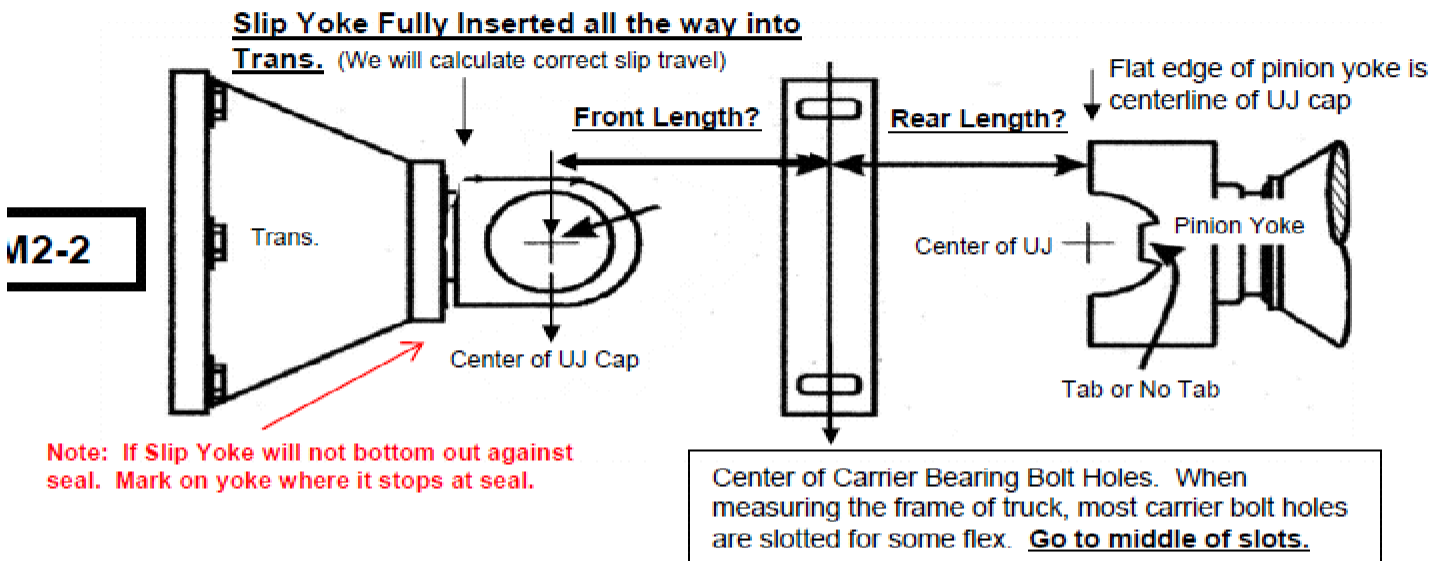

Note: If Slip Yoke will not bottom out against seal. Mark on yoke where it stops at seal.

Center of Carrier Bearing Bolt Holes. When measuring the frame of truck, most carrier bolt holes are slotted for some flex. **Go to middle of slots.**

_____ **Front Length** from center of UJ cap to center of carrier bearing bolt holes in frame.

_____ **Rear Length** from center of carrier bolt holes to flat edge of pinion yoke.

Boot seal on Trans? _____

How Long is boot? _____

Vehicle Type: _____

Trans. Type and output spline count _____

Differential Type if known _____

_____ UJ Series of Pinion Yoke. See UJ Identification for assistance or call us for assistance.

Pinion Yoke UJ Width: _____ Cap Diameter _____

Name _____ Phone _____

Address _____

Email _____ or Fax _____